

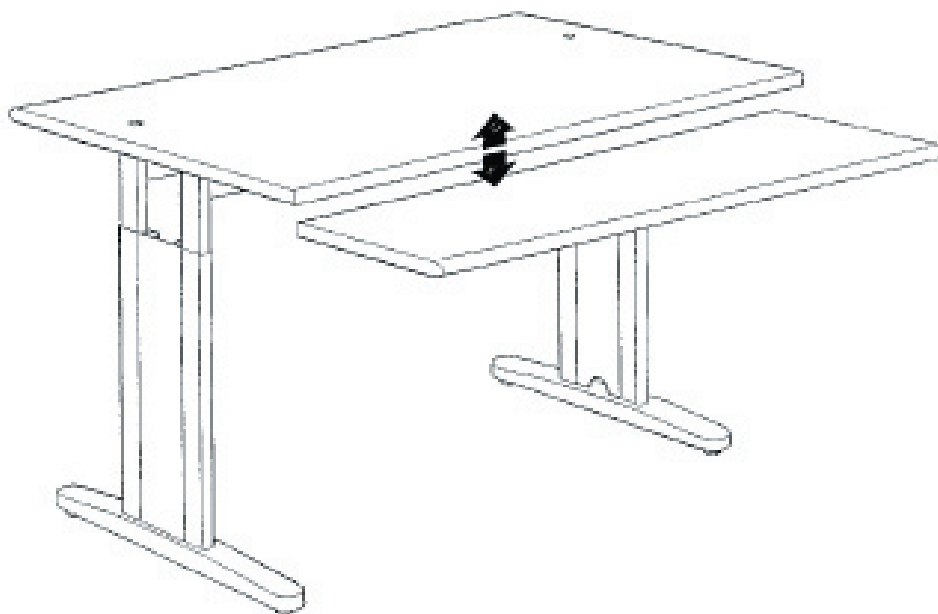

SIS-USA inc.
55 Wentworth Ave
Londonderry, NH
03053-7414
tel: 800-374-7438
tel: 603-432-4495
fax: 603-434-8456
www.sis-usa-inc.com



generation 4 Extreme

Tables/Universal tables/Combi tables+Combitables
flatpanel 9080, 9100, 9101, 9102, 9103, 9180, 9726, 9727, 9728, 9729

A : 1 x R011905



B : 4 x R011029
M8 x 50(LH)



C : 16 x R011267
6,2 x 20



D : 2 x R011218
3 x 25(PH)



E : 2 x R011123



F : 2 x R011024
M8 x 50(US)



G : 10 x R011265
Cable clamps



H : 10 x R011504
3,5 x 12



I : 3 x R011519
5 x 16(PH)



J : 4 x R011502
4 x 20mm

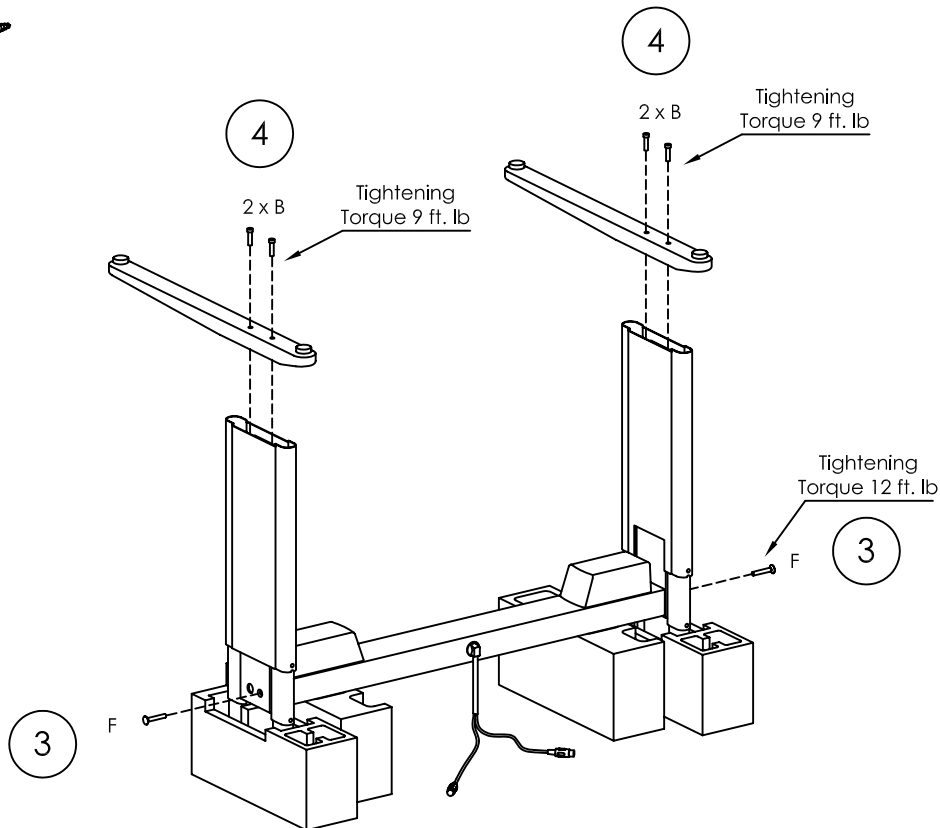
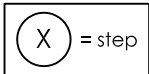
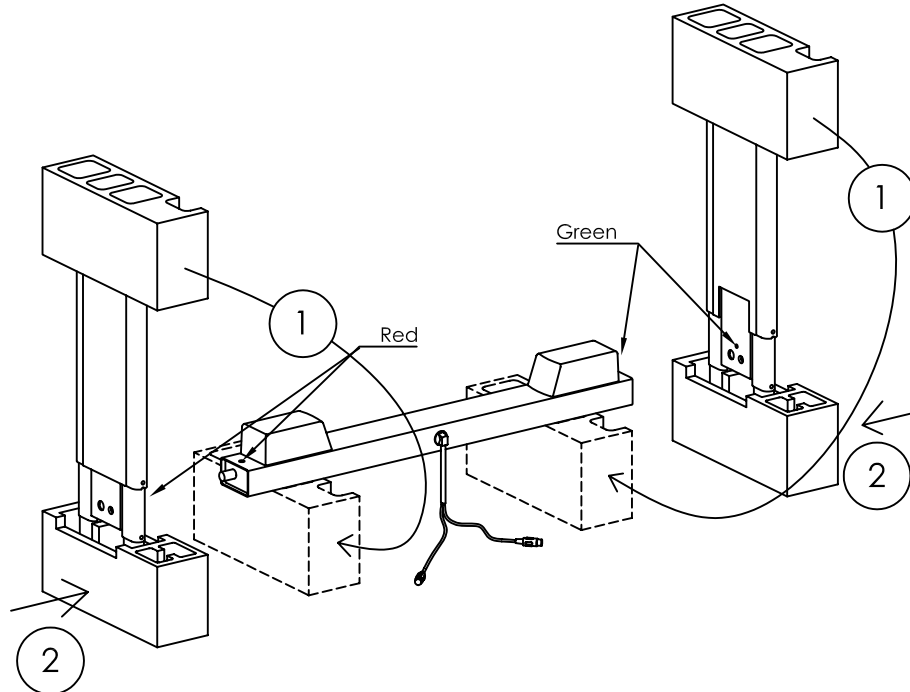

generation 4 Extreme

Tables/Universal tables/Combi tables+Combitables
flatpanel 9080, 9100, 9101, 9102, 9103, 9180, 9726, 9727, 9728, 9729

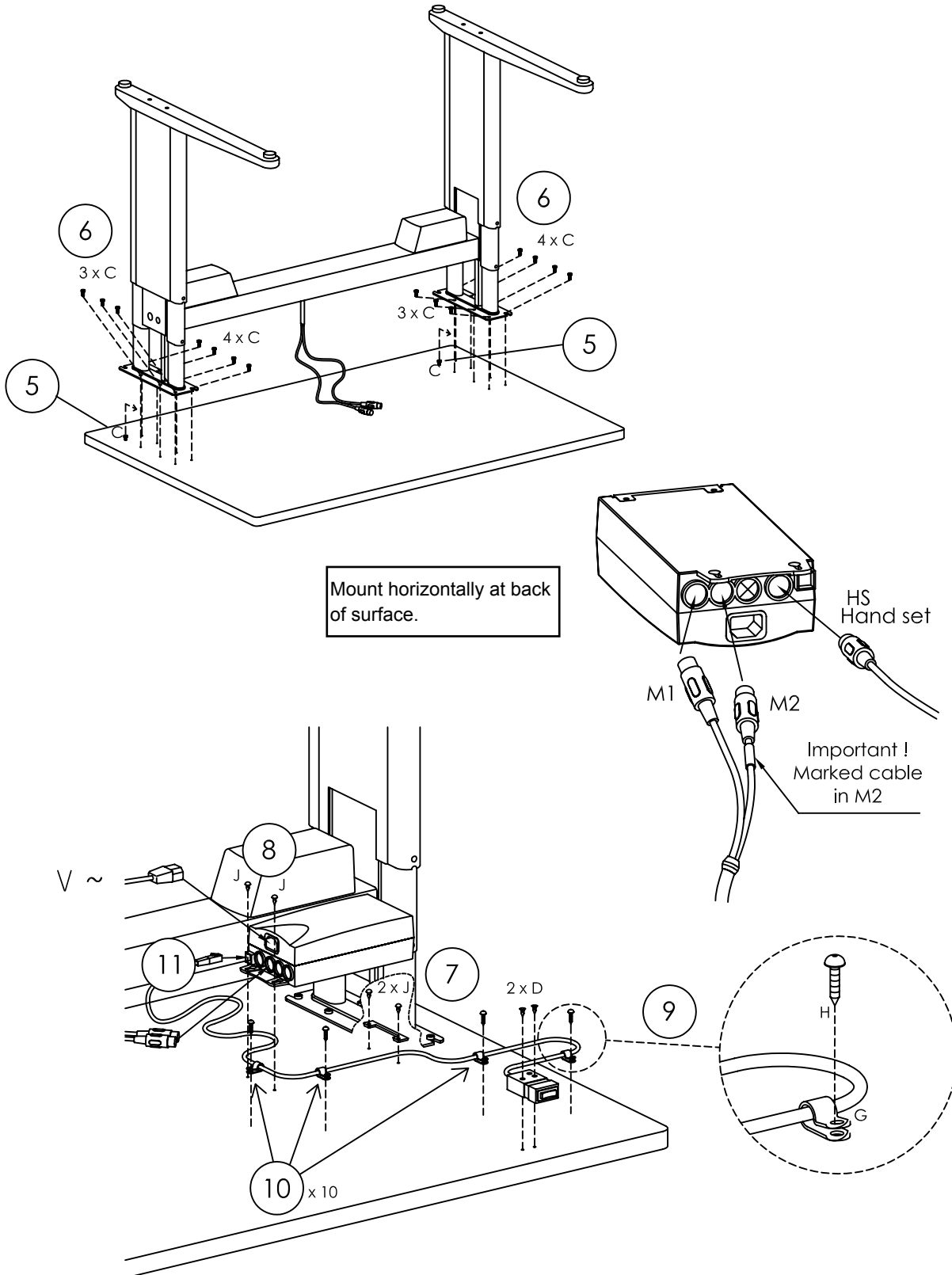

generation 4
Extreme

Tables/Universal tables/Combi tables+Combitables
flatpanel9080, 9100, 9101, 9102, 9103, 9180, 9726, 9727, 9728, 9729

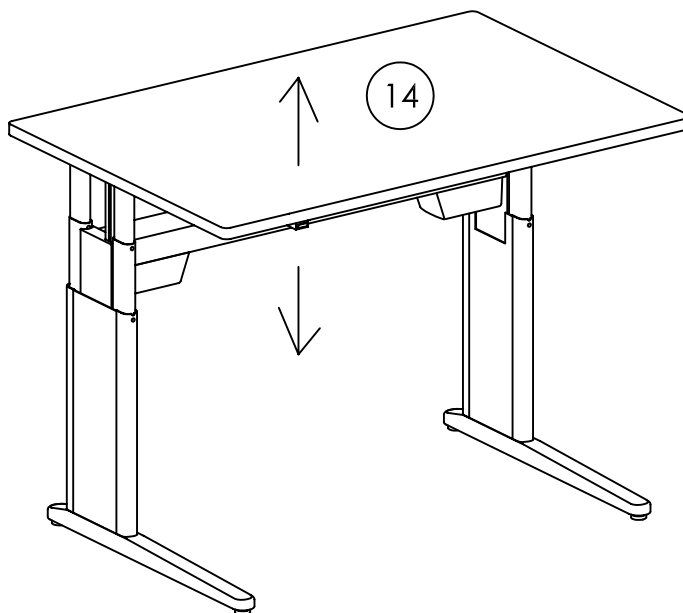
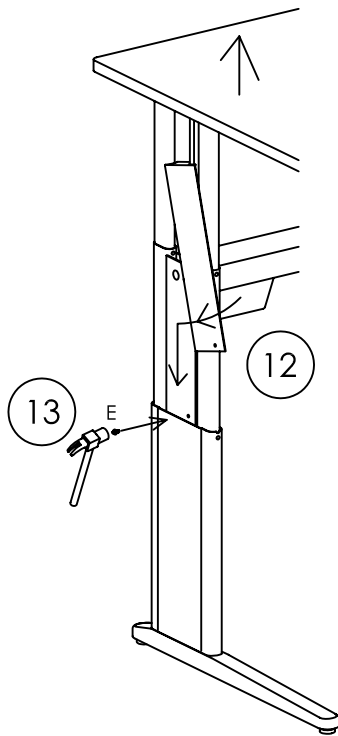

15

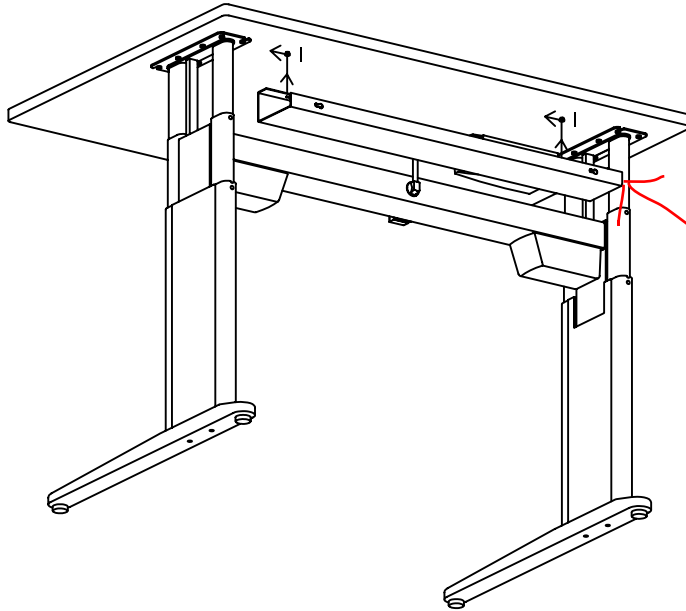

Do not mount the wire trough if not enough room when mounting keyboard arm for Duplex style

15

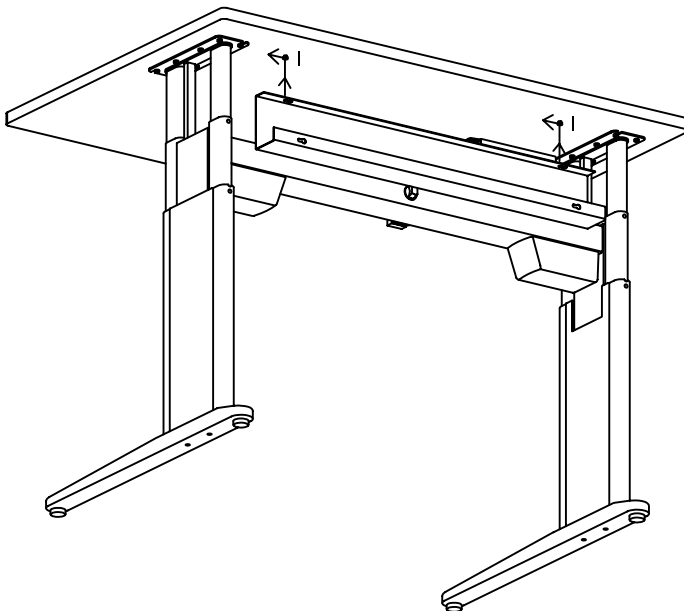



made for working

RIGHT HAND MECHANISM MOUNTING TEMPLATE AS VIEWED FROM BOTTOM. FOR USE IF APPLICATION IS NOT PREDRILLED.

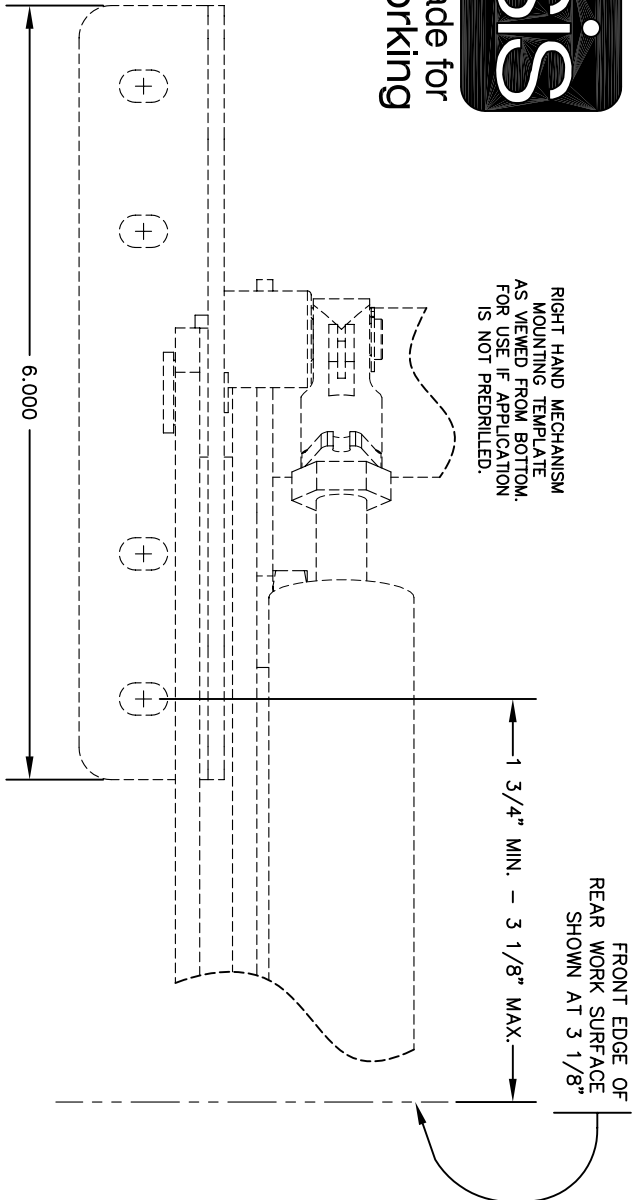

FRONT EDGE OF REAR WORK SURFACE SHOWN AT 3 1/8"

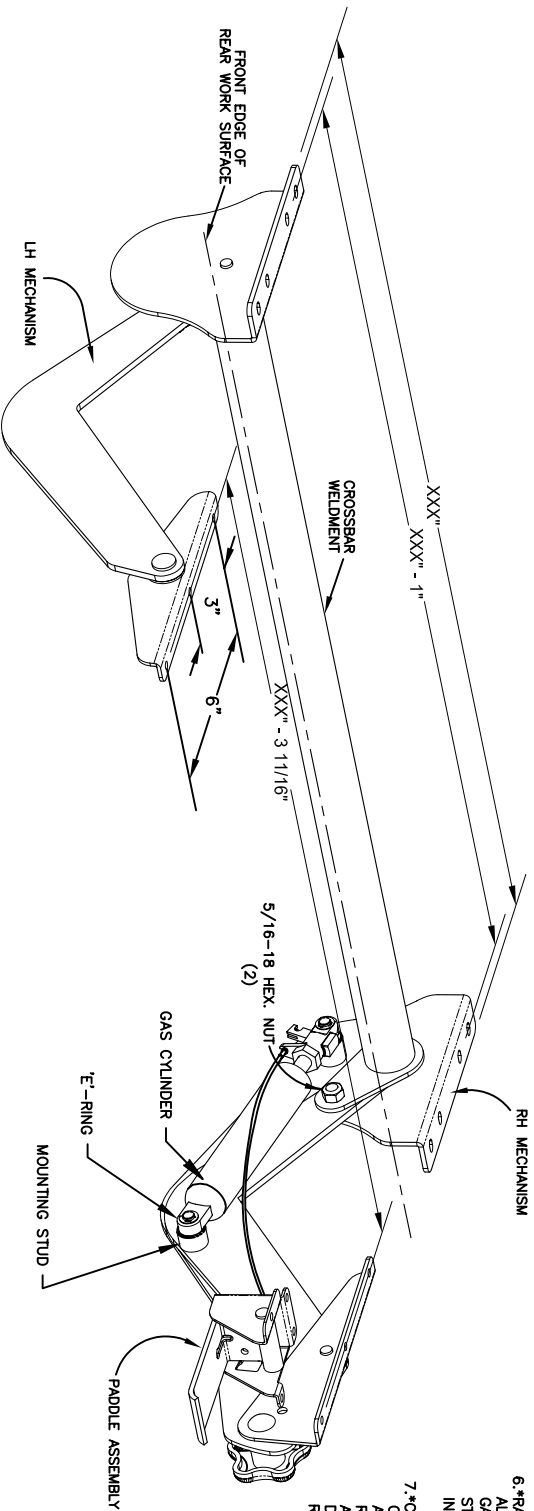

INSTALLATION INSTRUCTIONS

1. ASSEMBLE RIGHT HAND AND LEFT HAND MECHANISMS TO THE CROSSBAR WELDMENT USING TWO 5/16-18 HEX NUTS PROVIDED. (TORQUE TO 110 TO 130 INCH POUNDS).
2. IF THE WORK SURFACES ARE PREDRILLED PROCEED TO THE SECTIONS IDENTIFIED WITH AN ASTERISK.
3. USE THE TEMPLATE ON THIS SHEET TO LOCATE MOUNTING HOLES ON REAR WORK SURFACE FOR RIGHT HAND MECHANISM. FRONT HOLES OF MOUNTING BRACKETS MUST BE BETWEEN 1-3/4" & 3-1/8" FROM FRONT EDGE OF REAR WORK SURFACE. HOLE LOCATIONS FROM R.H. SIDE TO L.H. SIDE CAN BE DETERMINED BY SUBTRACTING 1" FROM XXX" (LENGTH OF UNIT).
- *4. SECURE UNIT TO REAR WORK SURFACE USING 8 SCREWS (OF 18 PROVIDED). #10 OR LARGER SCREWS ARE RECOMMENDED. THEY SHOULD BE AS LONG AS POSSIBLE DEPENDING ON WORK SURFACE THICKNESS.
4. FRONT WORK SURFACE MOUNTING - HOLE LOCATIONS FROM SIDE TO SIDE CAN BE DETERMINED BY SUBTRACTING 3-11/16" FROM XXX" (LENGTH OF UNIT). FRONT TO BACK LOCATION OF THE FRONT WORK SURFACE SHOULD BE MOUNTED TO PROVIDE A MINIMUM OF 1" CLEARANCE BETWEEN THE REAR AND FRONT WORK SURFACES TO ELIMINATE A POTENTIAL PINCH POINT.
- *5. MOUNT FRONT WORK SURFACE USING SIX SCREWS.
5. PADDLER ASSEMBLY MOUNTING - MOUNT CLOSE TO THE FRONT EDGE OF THE FRONT WORK SURFACE ON THE SIDE WITH FOUR SCREWS.
- *6. MOUNT THE PADDLER ASSEMBLY USING FOUR SCREWS.
6. RAISE & HOLD FRONT WORKSURFACE TO ALIGN MOUNTING STUD WITH MOUNTING HOLE ON GAS CYLINDER. SLIDE GAS CYLINDER OVER MOUNTING STUD AND FASTEN WITH E-RING. (2 PCS. ARE INCLUDED, BUT ONLY 1 P.C. IS NEEDED)
7. *CHECK RIGHT AND LEFT SIDE VERTICAL ALIGNMENT OF REAR AND FRONT WORK SURFACES. IF NOT ALIGNED, LOOSEN BUT DO NOT REMOVE LEFT SIDE HEX NUT. RAISE OR LOWER LEFT SIDE OF FRONT WORK SURFACE AS NEEDED. RE-TIGHTEN LEFT SIDE NUT WHILE MAINTAINING DESIRED POSITION OF LEFT SIDE OF WORK SURFACE. REPEAT FOR RIGHT SIDE IF NECESSARY.